



INTERNATIONAL APPLICATION PUBLISHED UNDER THE PATENT COOPERATION TREATY (PCT)

<p>(51) International Patent Classification 5 : E21B 43/10, 7/20, 33/14</p>	<p>A1</p>	<p>(11) International Publication Number: WO 93/25799 (43) International Publication Date: 23 December 1993 (23.12.93)</p>
<p>(21) International Application Number: PCT/EP93/01459 (22) International Filing Date: 8 June 1993 (08.06.93) (30) Priority data: 92201670.4 9 June 1992 (09.06.92) EP (34) Countries for which the regional or international application was filed: GB et al. (71) Applicant (for CA only): SHELL CANADA LIMITED [CA/CA]; 400 - 4th Avenue S.W., Calgary, Alberta T2P 2H5 (CA). (71) Applicant (for all designated States except CA): SHELL INTERNATIONALE RESEARCH MAATSCHAPPIJ B.V. [NL/NL]; Carel van Bylandtlaan 30, NL-2596 HR The Hague (NL).</p>	<p>(72) Inventors: WORRALL, Robert, Nicholas ; LOHBECK, Wilhelmus, Christianus, Maria ; CHOATE, Paul, Rogerson ; Volmerlaan 6, NL-2288 GD Rijswijk (NL). DONNELLY, Martin ; Westervoortsedijk 67D, NL-6827 AT Arnhem (NL). (74) Common Representative: SHELL INTERNATIONALE RESEARCH MAATSCHAPPIJ B.V.; Patents, Licensing and Trade Marks Division, P.O. Box 302, NL-2501 CH The Hague (NL). (81) Designated States: AU, CA, JP, KZ, NO, NZ, RU, UA, European patent (AT, BE, CH, DE, DK, ES, FR, GB, GR, IE, IT, LU, MC, NL, PT, SE), OAPI patent (BF, BJ, CF, CG, CI, CM, GA, GN, ML, MR, NE, SN, TD, TG). Published With international search report.</p>	

(54) Title: METHOD OF CREATING A WELLBORE IN AN UNDERGROUND FORMATION

(57) Abstract

A method of creating a wellbore in an underground formation is provided, the method comprising drilling a borehole (1) in the underground formation (3), lowering a casing (5) of a malleable material into the borehole, said casing being radially expansible against the borehole wall upon application of a radial load (7) and having a smaller elastic radial deformation than the surrounding formation upon application of said load. The radial load is applied to the casing thereby radially expanding the casing against the borehole wall so as to induce a compressive force between the casing and the surrounding formation.

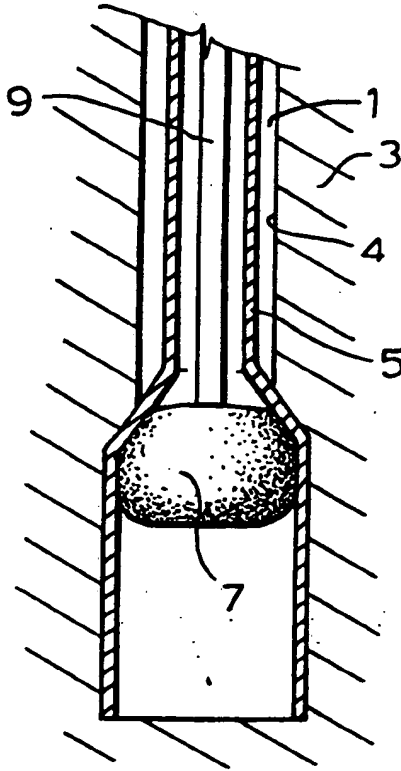

FOR THE PURPOSES OF INFORMATION ONLY

Codes used to identify States party to the PCT on the front pages of pamphlets publishing international applications under the PCT.

AT	Austria	FR	France	MR	Mauritania
AU	Australia	GA	Gabon	MW	Malawi
BB	Barbados	GB	United Kingdom	NL	Netherlands
BE	Belgium	GN	Guinea	NO	Norway
BF	Burkina Faso	GR	Greece	NZ	New Zealand
BG	Bulgaria	HU	Hungary	PL	Poland
BJ	Benin	IE	Ireland	PT	Portugal
BR	Brazil	IT	Italy	RO	Romania
CA	Canada	JP	Japan	RU	Russian Federation
CF	Central African Republic	KP	Democratic People's Republic of Korea	SD	Sudan
CG	Congo	KR	Republic of Korea	SE	Sweden
CH	Switzerland	KZ	Kazakhstan	SK	Slovak Republic
CI	Côte d'Ivoire	LI	Liechtenstein	SN	Senegal
CM	Cameroon	LK	Sri Lanka	SU	Soviet Union
CS	Czechoslovakia	LU	Luxembourg	TD	Chad
CZ	Czech Republic	MC	Monaco	TG	Togo
DE	Germany	MG	Madagascar	UA	Ukraine
DK	Denmark	ML	Mali	US	United States of America
ES	Spain	MN	Mongolia	VN	Viet Nam
FI	Finland				

METHOD OF CREATING A WELLBORE IN AN UNDERGROUND FORMATION

5 The invention relates to a method of creating a wellbore in an
underground formation, for example a wellbore for the production of
oil or gas. Generally, when a wellbore for oil or gas production is
created, a number of casings are installed in the borehole to
prevent collapse of the borehole wall and to prevent undesired
outflow of drilling fluid into the formation or inflow of fluid
from the formation into the borehole. The borehole is drilled in
intervals whereby each casing is installed after drilling a next
interval, so that a next casing to be installed is to be lowered
10 through a previously installed casing. In a conventional method of
creating a wellbore the outer diameter of the next casing is
limited by the inner diameter of the previously installed casing in
order to allow lowering of the next casing through the previous
casing. Thus, the casings are nested relative to each other, with
15 casing diameters decreasing in downward direction. Cement annuli
are provided between the outer surfaces of the casings and the
borehole wall to seal the casings from the borehole wall. As a
consequence of the nested arrangement of the casings, a relatively
large borehole diameter is required at the upper part of the
20 wellbore. Such a large borehole diameter involves increased costs
due to heavy casing handling equipment, large drill bits and
increased volumes of drilling fluid. Moreover, increased drilling
rig time is involved due to required cement pumping and cement
hardening.

25 It is an object of the invention to provide a method of
creating a wellbore in an underground formation, which method
eliminates the need for a relatively large borehole diameter in the
upper part of the wellbore and thereby overcomes the disadvantages
of the conventional method.

In accordance with the invention there is provided a method of creating a wellbore in an underground formation, comprising drilling a borehole in the underground formation, lowering a casing of a malleable material into the borehole, said casing being
5 radially expansible against the borehole wall upon application of a radial load and having a smaller elastic radial deformation than the surrounding formation upon application of said load, and applying said radial load to the casing thereby radially expanding the casing against the borehole wall so as to induce a compressive
10 force between the casing and the surrounding formation. After applying the radial load, the casing contracts slightly radially due to elastic relaxation. However, the elastic radial deformation of the formation does not completely vanish following the relaxation due to the elastic radial deformation of the formation being larger
15 than the elastic radial deformation of the casing. As a result thereof, a compressive force remains between the casing and the formation after relaxation, which compressive force ensures the casing being sealed to the formation. Thus, cement annuli are no longer required to seal the casing to the formation. Furthermore,
20 it is achieved that casings of uniform diameter can be applied in the wellbore. By expanding the casing in the borehole the outer diameter of the next casing to be installed is not limited by the inner diameter of the previous casing before expansion thereof so that a nested arrangement of the casings is not required. It is to
25 be understood that the casing being made of a malleable material implies that the casing material is capable of sustaining plastic deformation.

When a steel casing is applied, such casing normally has a smaller elastic radial deformation than the surrounding formation
30 when the casing is expanded against the borehole wall by application of a radial load to the casing.

Preferably the material of the casing is capable of sustaining a plastic deformation of at least 25% uni-axial strain, so that the casing can be sufficiently expanded in the borehole without rupture
35 of the casing material.

Advantageously the casing forms an intermediate casing located between a surface casing arranged in an upper part of the wellbore and a production casing arranged in a lower part of the wellbore.

When washouts occur in the borehole during drilling thereof, or when brittle formations are encountered, it can be desired to pump a sealing material in a fluidic state between the casing and the borehole wall prior to applying said radial load to the casing. For example, cement can be pumped in the annular space around the casing, which cement is allowed to harden after the casing has been expanded.

Plastic deformation of the casing can be promoted by heating the casing during radial expansion thereof.

A suitable casing joint to be employed for interconnecting two adjacent casings includes a section of a first casing provided with internal annular ribs having an inner diameter slightly larger than the outer diameter of a section of a second casing which extends into said section of the first casing. During expansion of the casing joint, the second casing is pressed against the ribs of the first casing whereby a metal to metal seal is achieved between said sections of the first and second casing. The ribs allow for some axial contraction of the second casing during radial expansion thereof.

An increase of speed of installing the casing in the borehole can be achieved by providing the casing continuously from a reel onto which the casing is stored before being lowered into the borehole, and unreeling from the reel during lowering into the borehole.

Furthermore, a considerable reduction of time and costs is achieved when the casing which is expanded in the borehole is also used as a drill string to drill the borehole. When for example the borehole is drilled using a tubing which is unreeled from a reel and to which a downhole motor driving a drill bit is connected (so-called coiled tubing drilling), the tubing can be expanded in the borehole to form a casing. The downhole motor and the drill bit remain in the borehole after expansion of the tubing.

The invention will now be described in more detail and by way of example, with reference to the accompanying drawings of which

Fig. 1 shows schematically a longitudinal section of a borehole in an underground formation and a casing lowered into the borehole;

Fig. 2 shows a hydraulic expansion tool in an unexpanded state positioned in a lower section of the casing of Fig. 1;

Fig. 3 shows the expansion tool in an expanded state;

Fig. 4 shows shows the expansion tool in the unexpanded state as the tool is moved to a next location;

Fig. 5 shows the the expansion tool in the expanded state at the next location; and

Fig. 6 shows an expander which is being moved through the casing.

Referring to Fig 1, there is shown a borehole 1 which has been drilled in an underground formation 3, and a steel casing 5 positioned concentrically in the borehole 1. The casing 5 is cylindrical and has a circular cross-section with an outer diameter smaller than the diameter of the borehole 1.

After the casing 5 has been lowered into the borehole 1, a hydraulic expansion tool 7 is lowered in an unexpanded state into a lower section of the casing 5, as shown in Fig. 2. The expansion tool 7 is connected to a surface pumping facility (not shown) by means of a hydraulic conduit 9. The tool 7 is expanded by operating the surface pumping facility thereby pumping hydraulic fluid through the conduit 9 and into the expander 7, as shown in Fig. 3. Pumping is stopped when the casing 5 at the location of the expansion tool 7 is expanded to an internal diameter slightly larger than the diameter of the borehole 1 as drilled. During expansion of the casing 5 against the borehole wall 4, the casing 5 undergoes elastic and plastic radial deformation, and the formation 3 surrounding the borehole 1 undergoes at least elastic radial deformation. It is to be understood that the elastic radial deformation of the casing 5 is significantly smaller than the plastic radial deformation thereof, and that the elastic radial

deformation of the surrounding formation 3 is significantly larger than the elastic radial deformation of the casing 5. After expansion of the casing 5 against the borehole wall 4, the hydraulic pressure in the tool 7 is removed allowing the tool 7 to contract to the unexpanded state, and allowing some elastic relaxation of the casing. The plastic deformation of the casing 5 remains, so that the elastic deformation of the underground formation 3 in the vicinity of the borehole wall 4 also remains. Thus, a compressive force remains between the casing 5 and the formation 3 due to the remaining plastic deformation of the casing 5.

As shown in Figs 4 and 5, after a lower section of the casing 5 has been radially expanded in this manner the expansion tool 7 is moved upward through the casing 5 in the unexpanded state and positioned at a next section of the casing 5, whereafter the tool 7 is expanded in order to expand the casing 5 similarly as described above. In this manner the casing 5 is expanded stepwise until the whole casing 5 has been radially expanded. Drilling of the wellbore 1 then proceeds using an underreamer drill bit (not shown), whereafter the next casing (not shown) is lowered through the previously expanded casing 5 to the newly drilled section of the wellbore 1.

The expander 22 shown in Fig. 7 can be used as an alternative to the hydraulic expansion tool 7. When the expander 22 is pushed downward through the casing 20 by an axial force F , the casing 20 is expanded to conform to the outer diameter of the expander 22, which outer diameter is selected such that the desired plastic radial deformation of the casing is achieved. By rotating the expander 22 during its movement through the casing 20 the axial friction between the expander 22 and the casing 20 is reduced. A further reduction of axial friction is achieved when the expander 22 is provided with rollers (not shown) which are capable of rolling along the inner surface of the casing 20 when the expander 22 is rotated, and by simultaneously rotating and axially moving the expander 22 through the casing 20. Radial deformation of the

- 6 -

casing 20 can be promoted by applying an internal pressure to the casing 20 when the expander 22 is moved through the casing 20.

5 In an alternative embodiment of the method according to the invention, a section of the interior of the casing in which a fluid is present is closed by means of two packers, whereafter the fluid is pressurised until the desired radial expansion of the casing is achieved. The alternative embodiment can also be used in conjunction with expansion by means of the hydraulic expansion tool or the expander described hereinbefore.

C L A I M S

1. A method of creating a wellbore in an underground formation, comprising drilling a borehole in the underground formation, lowering a casing of a malleable material into the borehole, said casing being radially expansible against the borehole wall upon
5 application of a radial load and having a smaller elastic radial deformation than the surrounding formation upon application of said load, and applying said radial load to the casing thereby radially expanding the casing against the borehole wall so as to induce a compressive force between the casing and the surrounding formation.
- 10 2. The method of claim 1, wherein said material of the casing is capable of sustaining a plastic deformation of at least 25% uni-axial strain.
3. The method of claim 1 or 2, wherein said casing forms an intermediate casing located between a surface casing arranged in an
15 upper part of the wellbore and a production casing arranged in a lower part of the wellbore.
4. The method of one of claims 1-3, wherein a sealing material in a fluidic state is pumped between the casing and the borehole wall prior to applying said radial load to the casing.
- 20 5. The method of one of claims 1-4, wherein at least part of said radial load is applied to the casing by moving an expander through the casing, which expander has a larger outer diameter than the inner diameter of the casing.
- 25 6. The method of claim 5, wherein said expander is provided with rollers which are capable of rolling along the inner surface of the casing when the expander is rotated, and the step of applying the radial load comprises simultaneously rotating the expander and moving the expander through the casing.

7. The method of claim 5 or 6, wherein an internal pressure is applied to the casing when the expander is moved through the casing so as to promote radial expansion of the casing.
8. The method of one of claims 1-4, wherein at least part of said radial load is applied to the casing by locating a hydraulic expansion tool in the casing and expanding said tool.
9. The method of one of claims 1-8, wherein the casing is heated during radial expansion thereof.
10. The method of one of claims 1-9, wherein said casing is stored on a reel before being lowered into the borehole and unreeled from the reel during lowering into the borehole.
11. The method of one of claims 1-10, wherein said casing is used as a drill string during drilling of the borehole.
12. The method substantially as described hereinbefore with reference to the drawings.
13. A wellbore created according to the method of one of claims 1-12.

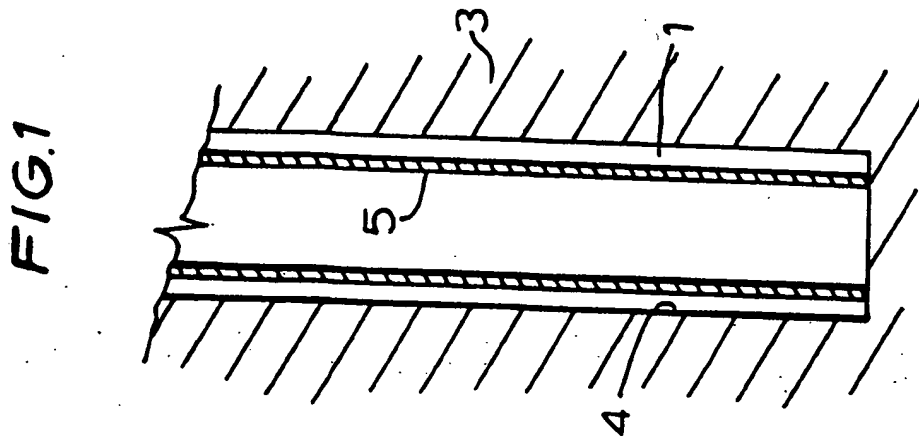
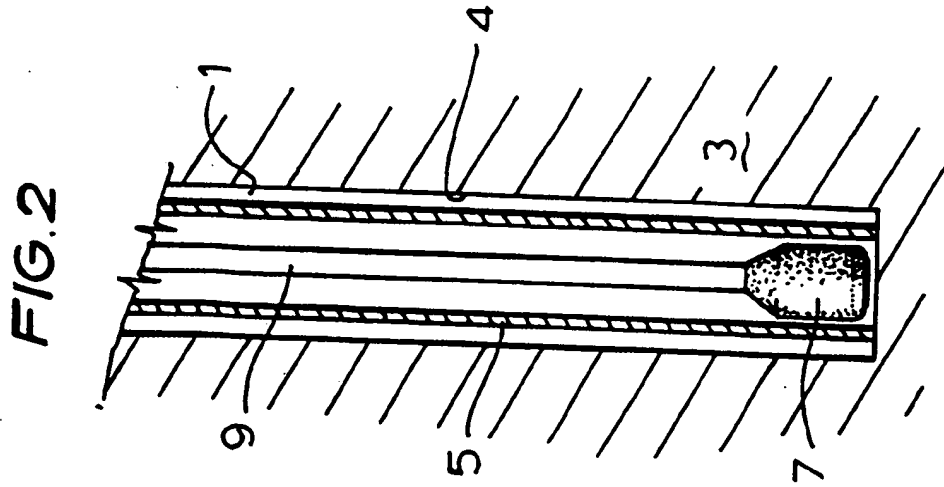
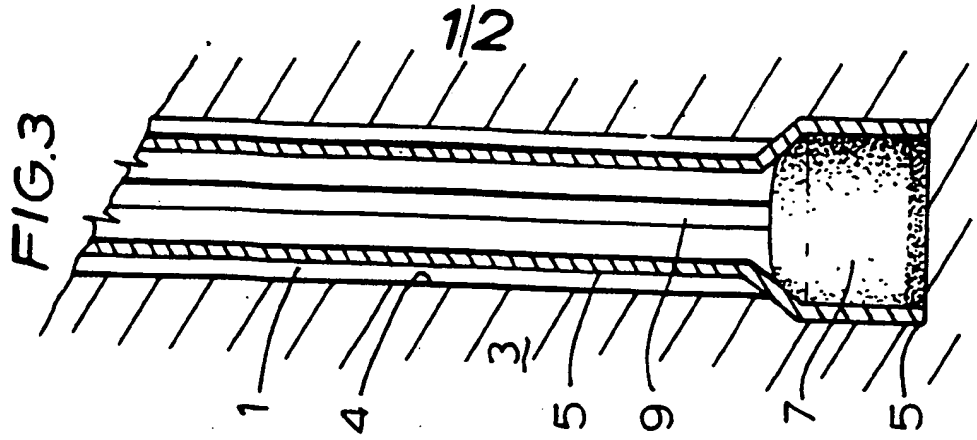

FIG. 6

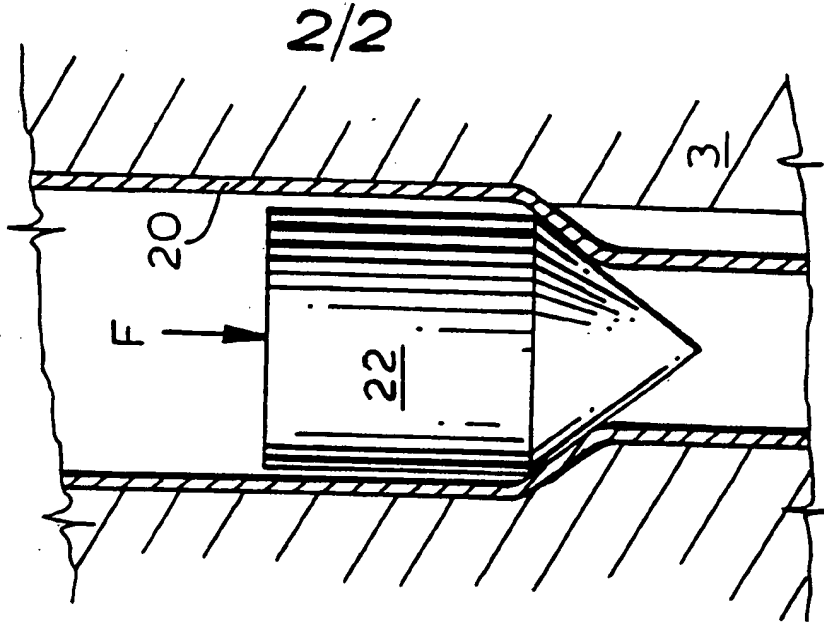

FIG. 5

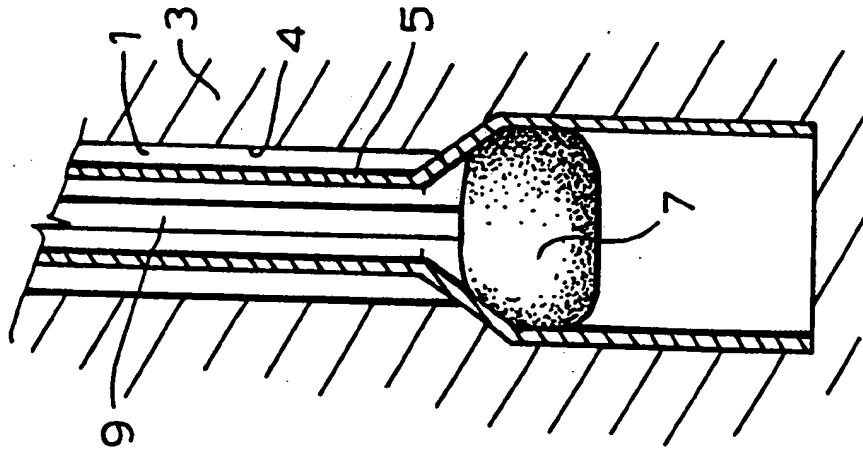
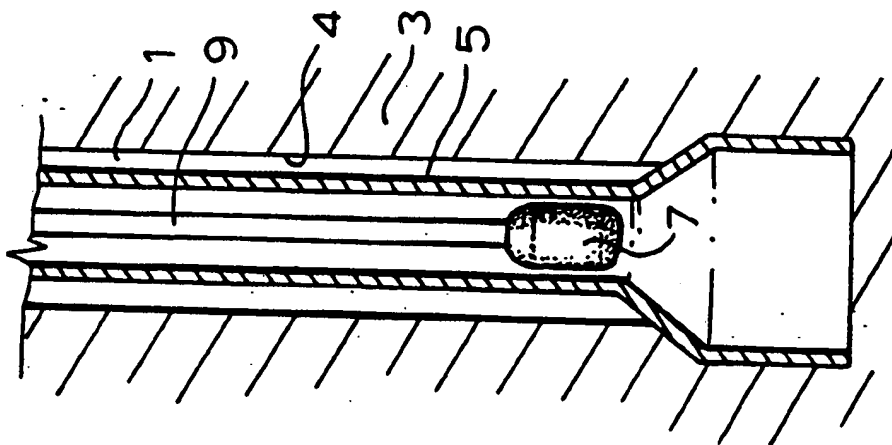

FIG. 4



INTERNATIONAL SEARCH REPORT

International Application No

PCT/EP 93/01459

I. CLASSIFICATION OF SUBJECT MATTER (if several classification symbols apply, indicate all)⁶
 According to International Patent Classification (IPC) or to both National Classification and IPC
 Int.Cl. 5 E21B43/10; E21B7/20; E21B33/14

II. FIELDS SEARCHED

Minimum Documentation Searched⁷

Classification System	Classification Symbols
Int.Cl. 5	E21B

Documentation Searched other than Minimum Documentation to the Extent that such Documents are included in the Fields Searched⁸

III. DOCUMENTS CONSIDERED TO BE RELEVANT⁹

Category ¹⁰	Citation of Document, ¹¹ with indication, where appropriate, of the relevant passages ¹²	Relevant to Claim No. ¹³
X	US,A,3 477 506 (B.C.MALONE) 11 November 1969 see column 4, line 38 - line 54 see column 6, line 30 - line 44; figures 1,2	1,2,8,12,13
Y	---	3-7,9-11
X	US,A,1 233 888 (R.E.LEONARD) 17 July 1917 see page 2, line 96 - line 104 see page 3, line 95 - line 97	1,12,13
Y	US,A,2 447 629 (V.J.BEISSINGER ET AL.) 24 August 1948 see column 5, line 48 - line 62; figures 1-5	3
	---	-/--

¹⁰ Special categories of cited documents:

- "A" document defining the general state of the art which is not considered to be of particular relevance
- "E" earlier document but published on or after the international filing date
- "L" document which may throw doubts on priority claim(s) or which is cited to establish the publication date of another citation or other special reason (as specified)
- "O" document referring to an oral disclosure, use, exhibition or other means
- "P" document published prior to the international filing date but later than the priority date claimed
- "T" later document published after the international filing date or priority date and not in conflict with the application but cited to understand the principle or theory underlying the invention
- "X" document of particular relevance; the claimed invention cannot be considered novel or cannot be considered to involve an inventive step
- "Y" document of particular relevance; the claimed invention cannot be considered to involve an inventive step when the document is combined with one or more other such documents, such combination being obvious to a person skilled in the art.
- "A" document member of the same patent family

IV. CERTIFICATION

Date of the Actual Completion of the International Search	Date of Mailing of this International Search Report
30 AUGUST 1993	13.09.93
International Searching Authority	Signature of Authorized Officer
EUROPEAN PATENT OFFICE	RAMELMANN K.

III. DOCUMENTS CONSIDERED TO BE RELEVANT (CONTINUED FROM THE SECOND SHEET)		
Category*	Citation of Document, with indication, where appropriate, of the relevant passages	Relevant to Claim No.
Y	US,A,3 693 717 (P.C.WUENSCHER) 26 September 1972 see column 3, line 41 - line 60	4
Y	EP,A,0 397 874 (TATARSKY PROEKTNY INSTITUT NEFTYANOI PROMYSHLENNOSTI) 22 November 1990 see page 8, line 3 - line 24; figures 7,8	5-7
Y	EP,A,0 377 486 (SUBTERRA LTD.) 11 July 1990 see abstract see column 2, line 47 - line 53	9,10
Y	US,A,3 945 444 (G.L.KNUDSON) 23 March 1976 see column 3, line 58 - column 4, line 6	11
A	EP,A,0 397 875 (TATARSKY PROEKTNY INSTITUT NEFTYANOI PROMYSHLENNOSTI) 22 November 1990 see page 5, line 33 - page 6, line 12	5-7
A	PATENT ABSTRACTS OF JAPAN vol. 10, no. 234 (M-507)14 August 1986 & JP,A,61 067 528 (NIPPON STEEL CORP.) 7 April 1986 see abstract	9
A	EP,A,0 353 309 (TATARSKY PROEKTNY INSTITUT NEFTYANOI PROMYSHLENNOSTI) 7 February 1990 see page 8, line 7 - line 12; figure 2	1

ANNEX TO THE INTERNATIONAL SEARCH REPORT
ON INTERNATIONAL PATENT APPLICATION NO.

EP 9301459
SA 75149

This annex lists the patent family members relating to the patent documents cited in the above-mentioned international search report. The members are as contained in the European Patent Office EDP file on
The European Patent Office is in no way liable for these particulars which are merely given for the purpose of information.

30/08/93

Patent document cited in search report	Publication date	Patent family member(s)	Publication date
US-A-3477506	11-11-69	None	
US-A-1233888		None	
US-A-2447629		None	
US-A-3693717	26-09-72	US-A- 3812912	28-05-74
EP-A-0397874	22-11-90	WO-A- 9005833	31-05-90
		AU-B- 623123	07-05-92
		AU-A- 3188389	12-06-90
		US-A- 5083608	28-01-92
EP-A-0377486	11-07-90	GB-A, B 2227545	01-08-90
US-A-3945444	23-03-76	None	
EP-A-0397875	22-11-90	WO-A- 9005831	31-05-90
		AU-B- 621350	12-03-92
		AU-A- 3189889	12-06-90
		US-A- 5014779	14-05-91
EP-A-0353309	07-02-90	SU-A- 1679030	23-09-91
		AU-B- 606777	14-02-91
		AU-A- 2939589	11-08-89
		CA-A- 1301635	26-05-92
		CN-A- 1034973	23-08-89
		WO-A- 8906739	27-07-89
		US-A- 4976322	11-12-90

EPO FORM P0077

For more details about this annex : see Official Journal of the European Patent Office, No. 12/82